

*Instruction Book For
Ascender Electrol*

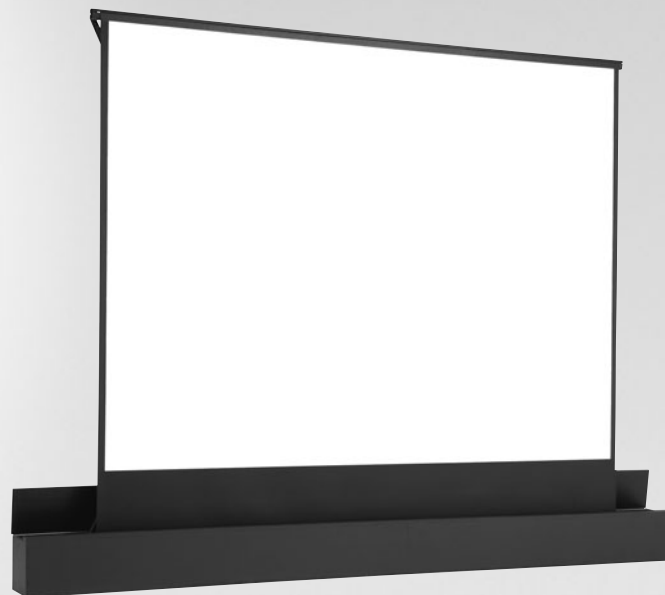

The
POWER *In*
PRESENTATION PRODUCTS



DA-LITE SCREEN COMPANY, INC.

3100 North Detroit Street
Post Office Box 137
Warsaw, Indiana 46581-0137
Phone: 574/267-8101
800-622-3737
Fax: 574/267-7804
[http:// www.da-lite.com](http://www.da-lite.com)
e-mail: info@da-lite.com

IMPORTANT SAFETY INSTRUCTIONS

When using your video equipment, basic safety precautions should always be followed, including the following:

1. Read and understand all instructions before using.
2. Position the cord so that it will not be tripped over, pulled, or contact hot surfaces.
3. If an extension cord is necessary, a cord with a current rating at least equal to that of the appliance should be used. Cords rated for less amperage than the appliance may overheat.
4. To reduce the risk of electric shock, do not disassemble this appliance. Contact an authorized service dealer when repair work is required. Incorrect reassembly can cause electric shock when the appliance is used subsequently.
5. The use of an accessory attachment not recommended by the manufacturer may cause a risk of fire, electric shock, or injury to persons.

SAVE THESE INSTRUCTIONS

INSTALLATION

1. The Ascender screen must be installed on a flat, level surface.
2. Refer to the chart below for minimum overhead clearance required to raise the screen.

	Diagonal Screen Size	Extended Height
VIDEO		
	100"	94"
	120"	104"
	150"	121"
	180"	139"
	200"	149"
HDTV		
	106"	86"
	119"	92"
	133"	99"
	159"	112"

3. Refer to figure 1 for electrical connections. Wiring designated as external is to be completed by installer conforming to local and national codes.
4. Remove packing paper from fabric roller. DO NOT use a knife or sharp object to remove the paper.

SCREEN OPERATION



CAUTION!

The arms of the screen are under high spring tension.

Do not stand over the screen while it is operating.

Do not sit, stand, or put anything on the screen case door.

The case door activates a safety switch inside the screen case. If you attempt to raise the screen while something is holding the door shut, the motor will reverse and retract the screen. The door must be fully closed to activate this switch. Be sure there is nothing holding the door ajar.

1. The Ascender screen can be operated by the included wall switch or by optional remote controls (IR or RF).
2. To raise the screen, simply push and release the wall switch. The screen will stop at its preset position. If you push the switch a second time while it is rising, the screen will stop. By pushing the switch a third time the screen will retract and close.
3. To lower the screen from the fully up position, press and release the wall switch and the screen will retract and close.
4. Test the screen by running it up and down a few times. Be prepared to stop the screen if needed.

NOTE: Excessive continuous operation may cause overheating. If this happens, the motor will shut off until it cools to normal operating temperature.

SCREEN ADJUSTMENT

The screen stop positions are preset at the factory. Should it be necessary to adjust for more or less travel proceed as follows. Refer to figure 2.

TO INCREASE SCREEN HEIGHT

1. Turn the white limit adjuster counterclockwise one-quarter turn at a time. Run the screen down about one foot and then back up to test the stop position. Repeat until the desired position is set.

NOTE: Do not adjust for more height than what was ordered. Adjusting too high may cause the arms to lock and not retract properly. There must be at least 1-1/2 wraps of fabric on the roller at all times.

TO DECREASE SCREEN HEIGHT

1. Turn white limit adjuster clockwise one-quarter turn at a time. Run the screen up to test the stop position. Lower the screen about one foot and turn limit adjuster again. Repeat until the desired position is set.

TO ADJUST THE DOWN POSITION

1. Raise the screen about one foot and stop. Turn the yellow limit adjuster counterclockwise one-quarter turn to increase the down travel.

NOTE: Do not adjust the screen down too far. This will strain the motor and screen. The lid of the box should just close when the motor stops.

1. Turn the yellow limit adjuster clockwise one-quarter turn at a time to decrease the amount of down travel. Run the screen down to test the stop position. Repeat until the desired position is set.

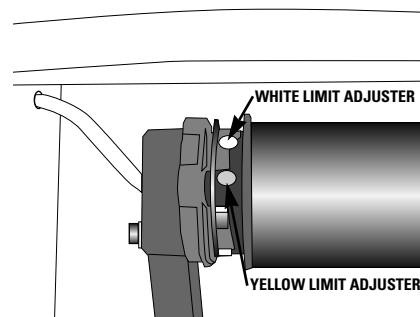

FIGURE 2

KEYSTONE ADJUSTMENT

The Ascender screen can be adjusted to reduce keystoneing of the video image.

This procedure requires two people. One to hold the arms and another to make the adjustments.

1. Raise the screen to the fully extended position.
2. Loosen the two lock nuts on the end of one arm. See figure 3.
3. Turn the adjusting nut and carefully push the arm in the required direction.
4. Tighten the lock nuts.
5. Repeat steps 2 to 4 for the other arm.

NOTE: Make sure that the screen surface does not rub against the edge of the case.

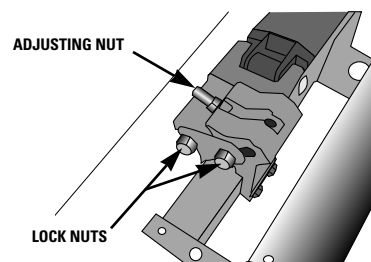
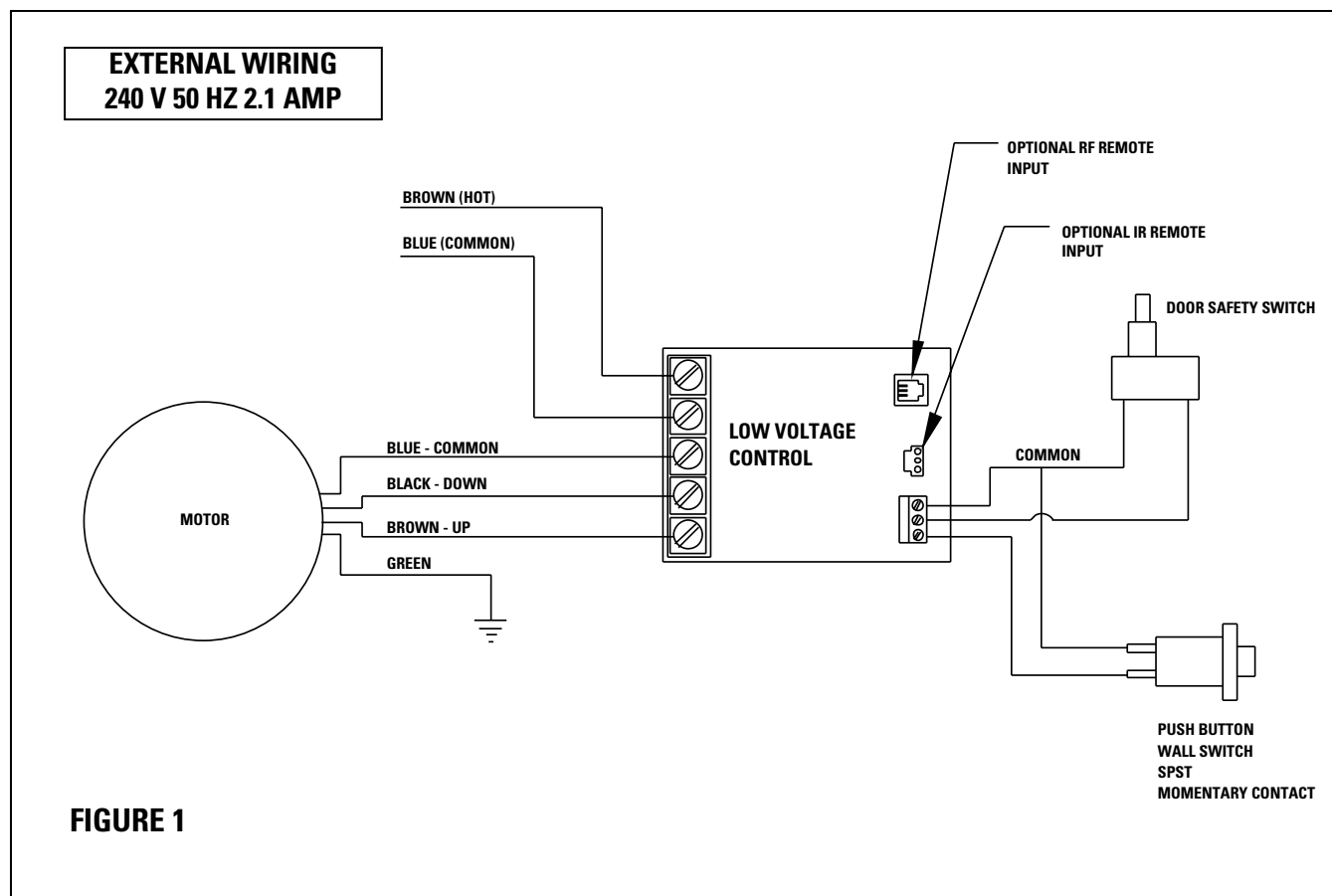
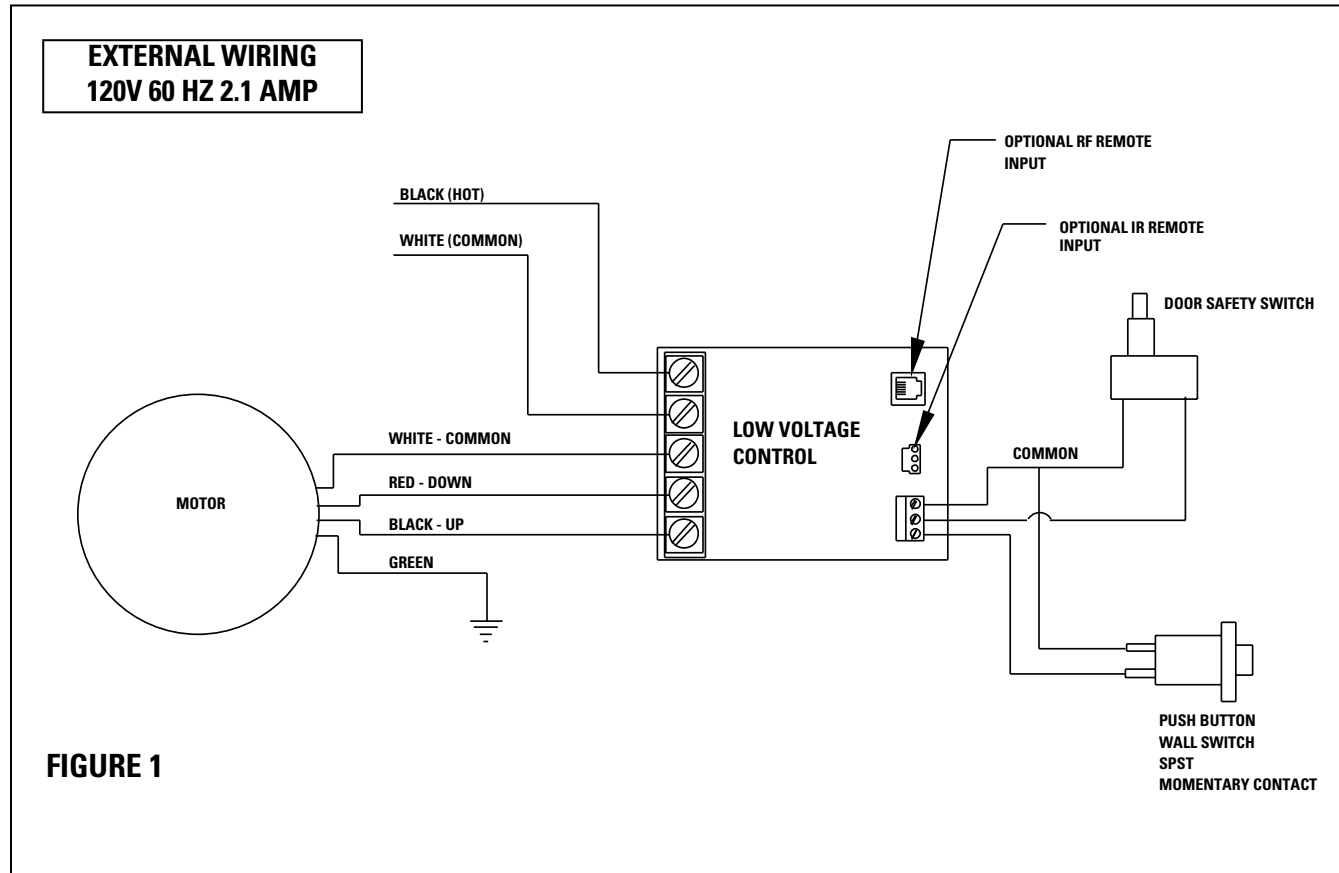

FIGURE 3

ASCENDER INSTALLATION



TROUBLESHOOTING

SYMPTOM	CAUSE	SOLUTION
<p>1. Screen will not operate or will not go "down". Motor does not hum.</p> <p>Motor hums.</p>	<p>(a) Blown fuse. (b) Tripped circuit breaker. (c) No power to operating switch or junction.</p> <p>Power at junction box</p> <p>(d) Thermal overload tripped. (e) Broken wire in the "down" position. (f) Defective motor, limit switch or capacitor. (g) Capacitor burned out.</p>	<p>(a) Replace fuse. (b) Reset circuit breaker. (c) Check above. Tighten all loose wire connections. Correct any improper connections.</p> <p>"Down" Position Check for power across black and white leads.</p> <p>(d) Let motor cool down for 15 minutes. Try again. (e) Check for continuity. Cut off old splice and reconnect.</p> <p>(f) Replace motor assembly. NOTE: Motor is a sealed assembly. (g) Replace motor assembly.</p>
<p>2. Screen will not move "up" Motor does not hum</p> <p>Motor hums.</p>	<p>(a) Blown fuse. (b) Tripped circuit breaker. (c) No power to operating switch or junction.</p> <p>Power at junction box</p> <p>(d) Thermal overload tripped.</p> <p>(e) Broken wire in the "up" position. (f) Defective motor, limit switch or capacitor. (g) Capacitor burned out.</p>	<p>(a) Replace fuse. (b) Reset circuit breaker. (c) Check above. Tighten all loose wire connections. Correct any improper connections.</p> <p>"Up" Position Check for power across red and white leads.</p> <p>(d) Let motor cool down for 15 minutes. Try again. (e) Check for continuity. Cut off old splice and reconnect.</p> <p>(f) Replace motor assembly. NOTE: Motor is a sealed assembly. (g) Replace motor assembly.</p>

TROUBLESHOOTING

SYMPTOM	CAUSE	SOLUTION
3. Incorrect stopping position in downward direction.	(a) "Down" limit switch out of adjustment	(a) See installation instructions.
4. Incorrect stopping position in upward direction.	(a) "Up" limit switch out of adjustment	(a) Adjust "up" limit switch. See installation instructions
5. Noise. NOTE: Screen will operate with a low pitched hum.	(a) Grinding due to foreign object in screen rubbing on roller or fabric. (b) Gear noise.	(a) Remove foreign object. (b) Replace motor assembly.
6. Coasting.	(a) Defective brake.	(a) Replace motor assembly.